



**Connection:** BSP female threaded version / Solvent socket version

**Dimensions:** threaded  $\varnothing$  3/8" to 3"/ solvent  $\varnothing$  16 to  $\varnothing$  90 mm.

**Minimal Temp** + 0°C

**Maximal Temp** + 60°C

**Maximal Pressure:** 10 Bars

**Characteristics:** Y Check Ball Valve

Vertical / Horizontal installation

Checking Plug

**Made of (Material):** U-PVC

### General Features:

Ball Check valve

Vertical with flow up fluid / horizontal (note the flow direction indicated by the arrow on the body.

Female / female BSP

Checking Plug

Low pressure loss

### USE:

Pour water supply, water distribution and water evacuation

Temp. Minimal - Ts: 0°C

Temp. Maximal - Ts: + 60°C

Pressure maximal NP: 10 bar

### PRESSURE LOSS DIAGRAM:

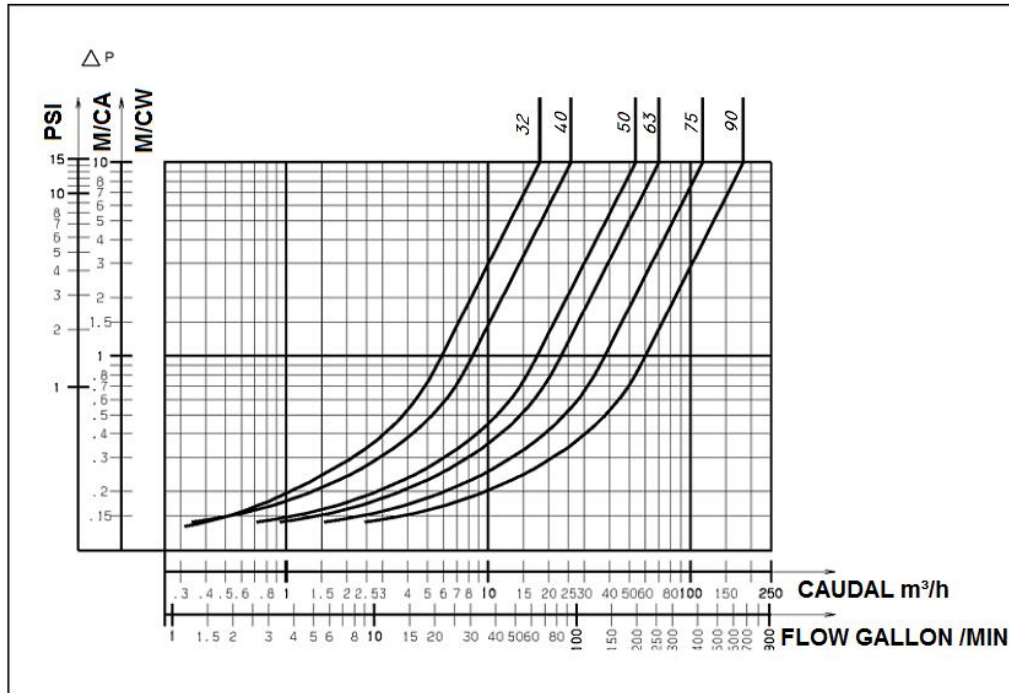

### Observations:

This check valve it is offered with U-PVC ball either and EPDM Ball

Female / Female thread, BSP cylindrical as per EN ISO 228-1 :2003 standard, ISO 7-1:1994 , DIN EN 10226-1:2004-10.

For solvent version as per standards: EN ISO 1452-3:2011 and ISO 727-1:2002 and pipes produced as per standards: EN ISO 1452-2:2010, ISO 161-1:1996 and ISO 11922-1:1997.

### SPARE PARTS:

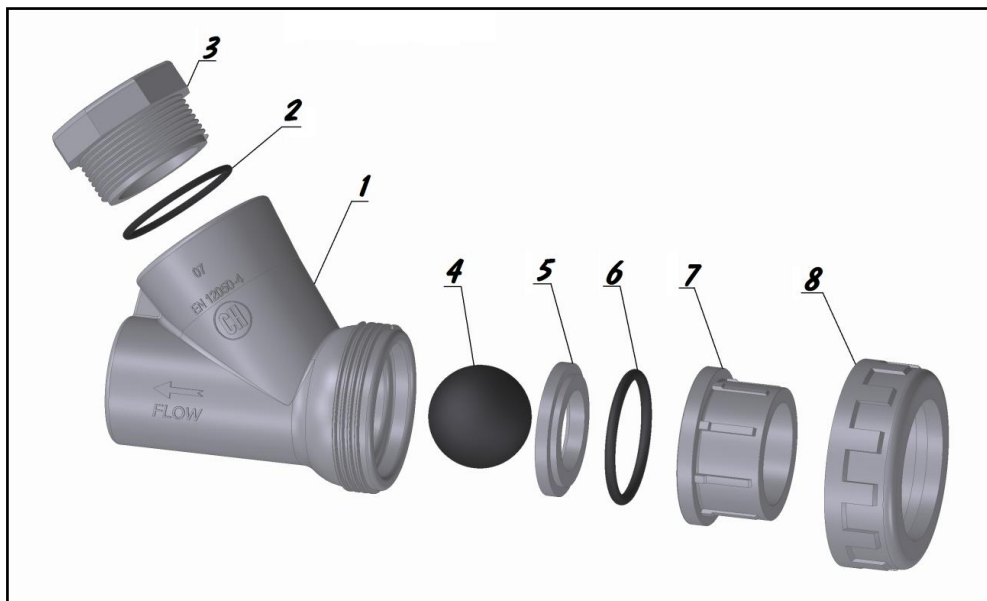

Nº	SPARE	MATERIAL
1	BODY	PVC-U
2	CAP O-RING	EPDM
3	CAP	PVC-U
4	BALL	EPDM
5	GASKET	PVC-U
6	O-RING	EPDM
7	SOCKET	PVC-U
8	NUT	PVC-U

### DIMENSIONS:

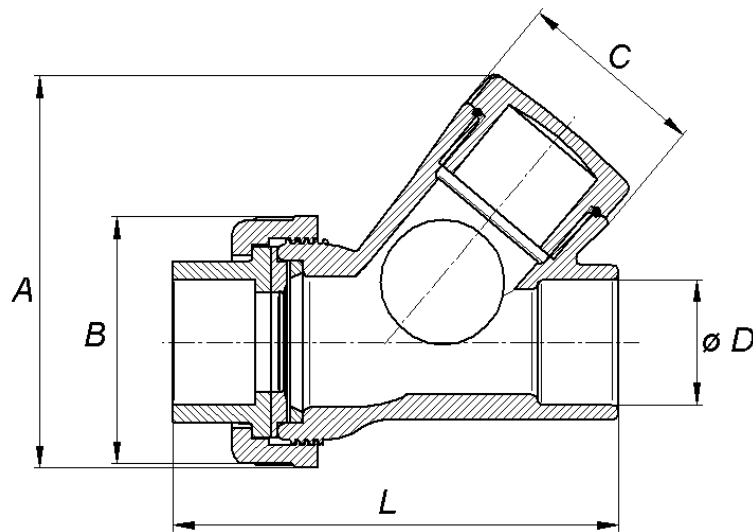

DIMENSIONS (mm)						
DN	A	B	C	D (solvent)	D (thread)	Weight (kg)
10	78	49	34	16	3/8"	0,113
15	78	49	34	20	1/2"	0,103
20	92	57	41	25	3/4"	0,161
25	104	67	59	32	1"	0,227
32	127	81	61	40	1 1/4"	0,440
40	158	99	71	50	1 1/2"	0,739
50	181	112	90	63	2"	1,186
65	238	154	114	75	2 1/2"	3,510
80	286	178	137	90	3"	4,305

### STANDARDS:

Produced as per standard ISO 9001: 2015

DIRECTIVE 97/23/CE : Products excluded from directive (Article 1, § 3.2)

According to standard for pumping stations NF EN 12050-4

Cylindrical female BSP thread as per standard ISO 228-1

Solvent connection as per standard EN ISO 1452-2 :2010



# INSTALLATION INSTRUCTIONS CHECK VALVE “Y” PN 10

Release 0

Date: 06/03/2019

Page 4 / 4

## POSITIONS:

Vertical with flow up fluid / horizontal

## RECOMMENDATIONS FOR USE:

Warnings and advices, technical indications, a proposal does not therefore imply a guarantee. It is at your responsibility for responsive and adequate use and the choose for the right product regarding the real working conditions on site.

## ASSEMBLY INSTRUCTIONS :

Check the real conditions of use before valve installation (fluid nature, temperature and pressure).

Pre installation of valves in order to isolate the pipe and easy installation.

Check that the installed check valves are as per current standards.

Please before assembly clean the pipe with a cleaner to remove impurities that can affect to the proper function of check valves.

Verify correct alignment of pipes up and down, a deficient alignment can affect negatively on the normal function.

Check the pipes line up and down, the valve will not absorb the deviation. The result can be a problem on sealing, a deficient movement for closing inside parts on valve, or also breaks and leaks.

So therefore present the valve in position and check properly the assembly conditions.

Before assembly check please the good condition of male / female threads.

Wedge and support the pipes that are not yet on a definitive fixing point that will avoid limitations on the check valve.

Use only a suitable spanner key to install a threading valve, that threading must be done carefully on direction of thread exclusively, do not tight the valves that are positioned on a pipe clip or fixing point.

On a valve installation, tight moderately the valves. Don't block the extensions of the key that could cause a body deformations or breaks.

On a modification on flow sense or in the presence of another device...please keep safe the check valve enough from that device in order o avoid risk of turbulence zone that will cause a premature deterioration of valve. (Please very important: between 3 to 5 times the nominal diameter up and down of flow.

On pump discharge pressure it is recommended to install the check valve on correct place as per NF CR 13932